

## PolyChannel Programmable Digital Transceiver

*WaveRunner PCI* adds a high performance software defined radio capability to any computer with a PCI backplane. The unique polychannel architecture combines the flexibility, performance, and precision of advanced digital transceiver chips with a modern analog IF front-end to address a broad range of both narrowband and wideband applications. The industry standard PCI interface simplifies programming and eases the transition from a desktop development environment to an embedded target platform. A single module contains independent receive and transmit threads that share a common command and data interface to the host processor.

The receiver accepts an analog IF input through an SMB connector located on the front panel. The signal is routed through a digitally controlled attenuator and buffer amplifier immediately preceding the analog anti-alias filter. A second amplifier stage boosts the signal to match the input range of the A/D converter. The second IF produced by the A/D converter is passed to a digital downconverter that can be configured for one to eight independent output channels. Each channel tunes to a signal of interest and performs amplitude adjustment based on gain control settings. The complex data samples produced by the downconverter are stored in a FIFO that is accessed through DMA transfers initiated by the host or transceiver.

The transmitter data flow begins at the host interface with the DMA transfer of samples between the processor and data FIFO located on the transceiver module. The samples are rate buffered out of the FIFO to match the clock frequency at the input of the digital upconverter. The upconverter filters and interpolates from one to eight independent channels to produce a single wideband digital IF at the D/A converter input. The resulting analog signal is passed through two conversion stages to produce a final IF that is supplied through an SMB coaxial connector located on the front panel.

- ▲ Industry Standard PCI Form Factor
- ▲ 70 MHz Analog IF (Baseband Optional)
- ▲ 20 MHz Analog Receive Bandwidth
- ▲ 40 MHz Analog Transmit Bandwidth
- ▲ 5 MHz Maximum Signal Bandwidth
- ▲ Up to 8 Transmit and Receive Channels
- ▲ Up to 90 dB Linear Dynamic Range
- ▲ PCI Bus Master With Auto DMA Feature
- ▲ 32/64-bit and 33/66 MHz PCI Support
- ▲ Front Panel Control for Synchronization
- ▲ Includes Windows 95/98/NT/2000 Drivers
- ▲ Includes Waveformer Configuration Tool

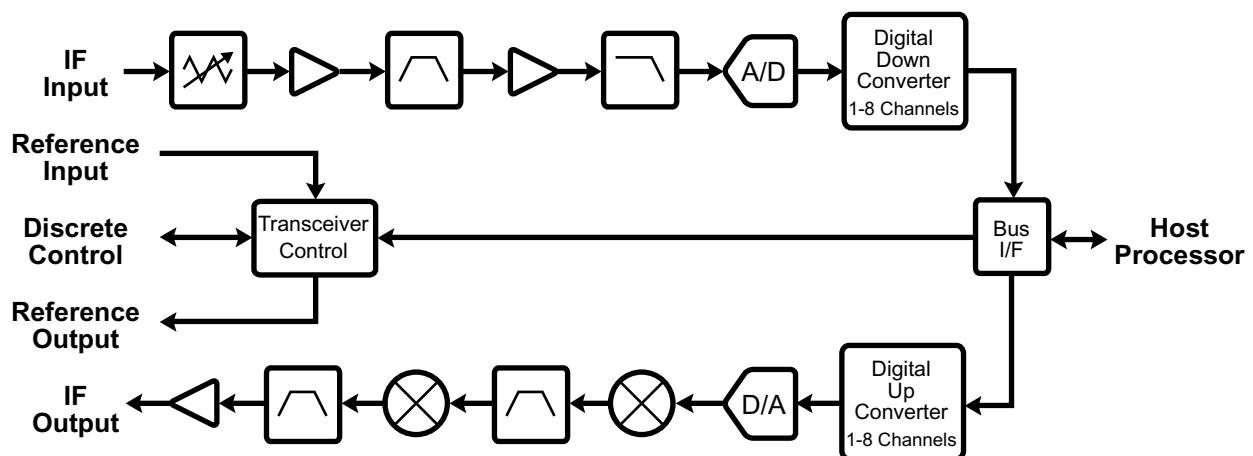

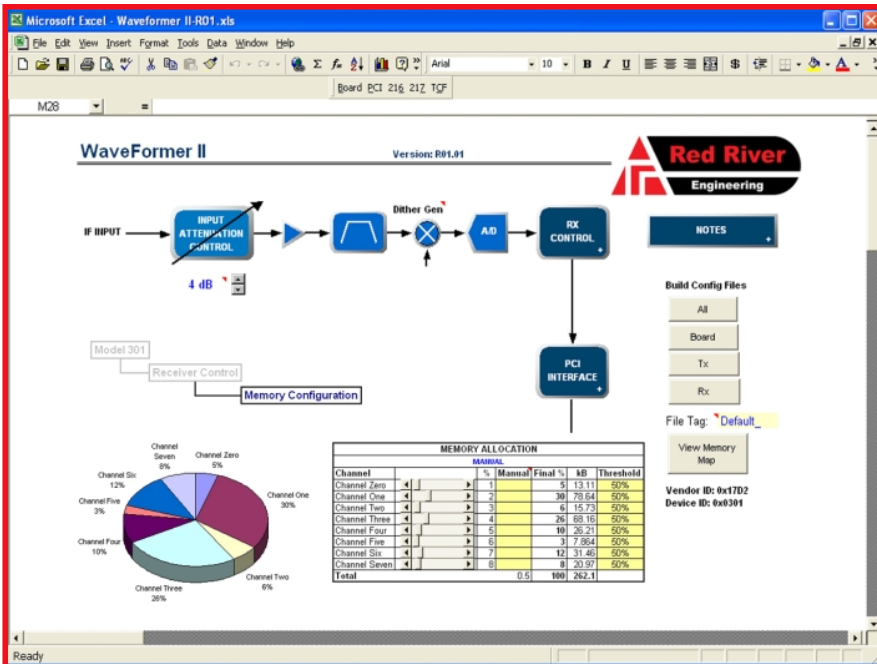

The WaveFormer configuration tool simplifies transceiver programming.

WaveRunner PCI offers a simple memory-mapped host interface referenced to a single base address. The host processor has direct access to all control registers, including the receiver input attenuator level, FIFO memory allocation by channel, downconverter (ISL5216) configuration space, upconverter (ISL5217) configuration space, local command/status, and transceiver data flow control. The interface includes an interrupt to alert the host of an error condition or data service request.

WaveRunner PCI programming is simplified by the WaveFormer configuration tool that automates the process of computing register values based on the desired performance characteristics of the transceiver. The user enters configuration information through a series of menu-driven spreadsheets that accept input based on available register options. The spreadsheets also perform error checking to eliminate configuration conflicts and graphically display key performance parameters in simple block diagrams and frequency response plots. The configuration tool generates a file containing the complete memory map that can be easily uploaded from the host.

### Typical Applications

- ▲ Multi-Mode Base Stations (1G, 2G, 2.5G, 3G)
- ▲ Beamforming / TDOA (Smart Antenna, E911)
- ▲ Military Communications (AM, FM, FSK, PSK, DAMA)
- ▲ Multi-Mode Software Radio
- ▲ Multi-Mode Wireless Local Loop
- ▲ Satellite Communications

### Specification Summary

#### ▲ Receiver

- 70 MHz IF Input (20 MHz BW)
- 15 dBm Input Power (Full Scale)
- +5 dBm 3<sup>rd</sup> Order Intercept Point
- 40 dB Analog Gain Control
- 14-bit, 56 MSPS A/D Converter
- Intersil ISL5216 Downconverter
- 1-8 Independent Output Channels
- 256 kbyte Configurable Data FIFO
- 5 MHz Maximum Signal Bandwidth
- Digital Automatic Gain Control
- 90 dB Linear Dynamic Range (30kHz)

#### ▲ Transmitter

- 1-8 Independent Input Channels
- 256 kbyte Configurable Data FIFO
- Intersil ISL5217 Upconverter
- 10 MSPS Max Complex Input
- 14-bit, 75 MSPS D/A Converter
- 5 MHz Maximum Signal Bandwidth
- 70 MHz IF Output (40 MHz BW)
- 15 dBm Output Power (Full Scale)
- +5 dBm 3<sup>rd</sup> Order Intercept Point
- 70 dB Spur-Free Dynamic Range

#### ▲ Board

- PCI Short Compliant Physical
- 32/64-bit, 33/66 MHz PCI Bus
- Built-In TDMA Scheduler
- SMB Coaxial Analog I/O
- 10 MHz 3 ppm Local Reference
- 5 to 25 MHz Reference Input

#### ▲ Options

- Baseband Analog I/O
- PMC, CPCI, VME Solutions Available
- Baseband Analog Interface
- Customization Available by Request

#### For further information, contact:

#### Red River

797 North Grove Rd, Suite 101  
 Richardson, TX 75081  
 Phone: (972) 671-9570  
 Fax: (972) 671-9572  
[www.red-river.com](http://www.red-river.com)