

M82 - 16 Binary Inputs

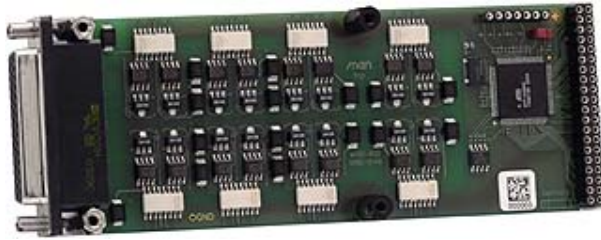

- 16 fast 20kHz inputs
- 0..40V input voltage
- Constant current inputs
- Hysteresis function
- Interrupt generation
- Optical isolation from the system (500VDC)
- Optical isolation between the channels (100VDC)

The M82 is based on the M-Module ANSI mezzanine standard. It can be used as an I/O extension in any type of bus system, i.e. CPCI, PXI, VME or on any type of stand-alone SBC. Appropriate M-Module carrier cards in 3U, 6U and other formats are available from MEN or other manufacturers.

The M82 is a 16-channel fully isolated input M-Module with latching and comparator capabilities for industrial applications. A current limit for each

input guarantees an input voltage range of 0 to 40V. Each input signal edge generates a maskable interrupt for each channel. The voltage-sensitive inputs have a hysteresis function.

Typical I/O applications include automated test equipment, simulators and PLC-like applications with different voltage requirements.

The M82 is software-compatible with the M31.

Technical Data

Binary Inputs

- FET constant current source inputs
 - 5.6mA typ.
- Input voltages and currents:
 - 0..40V max.
 - 5.5V, $\pm 0.5V$ (switching voltage 0) @ 3mA min., 3.3mA typ., 4mA max.
 - 9.5V, $\pm 0.5V$ (switching voltage 1) @ 4mA min., 5.6mA typ., 10mA max.
 - 15.2V, $\pm 0.5V$ (switching voltage 2) @ 4mA min., 5.6mA typ., 10mA max.
- Switching Times
 - Rise time: 4.2 μ s typ.
 - Fall time: 32 μ s typ.

Miscellaneous

- Hysteresis function
- Interrupt generation with maskable interrupt

Peripheral Connections

- Via front panel on a shielded 44-pin HD-Sub receptacle connector

M-Module Characteristics

- A08, D16, INTA, INTB, IDENT

Electrical Specifications

- Isolation voltage:
 - 500V DC between isolated side and digital side
 - All channels are optically isolated (100V between the channels)
- Supply voltage/power consumption: +5V (4.85V..5.25V), 220mA typ.
- MTBF: 185,000h @ 50°C

Mechanical Specifications

- Dimensions: conforming to M-Module Standard
- Weight: 72g

Environmental Specifications

- Temperature range (operation):
 - 0..+60°C or -40..+85°C
 - Airflow: min. 10m³/h
- Temperature range (storage): -40..+85°C
- Relative humidity range (operation): max. 95% non-condensing
- Relative humidity range (storage): max. 95% non-condensing
- Altitude: -300m to + 3,000m
- Shock: 15g/11ms
- Bump: 10g/16ms
- Vibration (sinusoidal): 2g/10..150Hz

Safety

- PCB manufactured with a flammability rating of 94V-0 by UL recognized manufacturers

EMC

- Tested according to EN 55022 / 1999-05 (radio disturbance) and EN 55024 / 1999-05 (immunity) with regard to CE conformity

Software Support

- MEN Driver Interface System (MDIS for Windows, Linux, VxWorks, QNX, RTX, OS-9)

Diagram

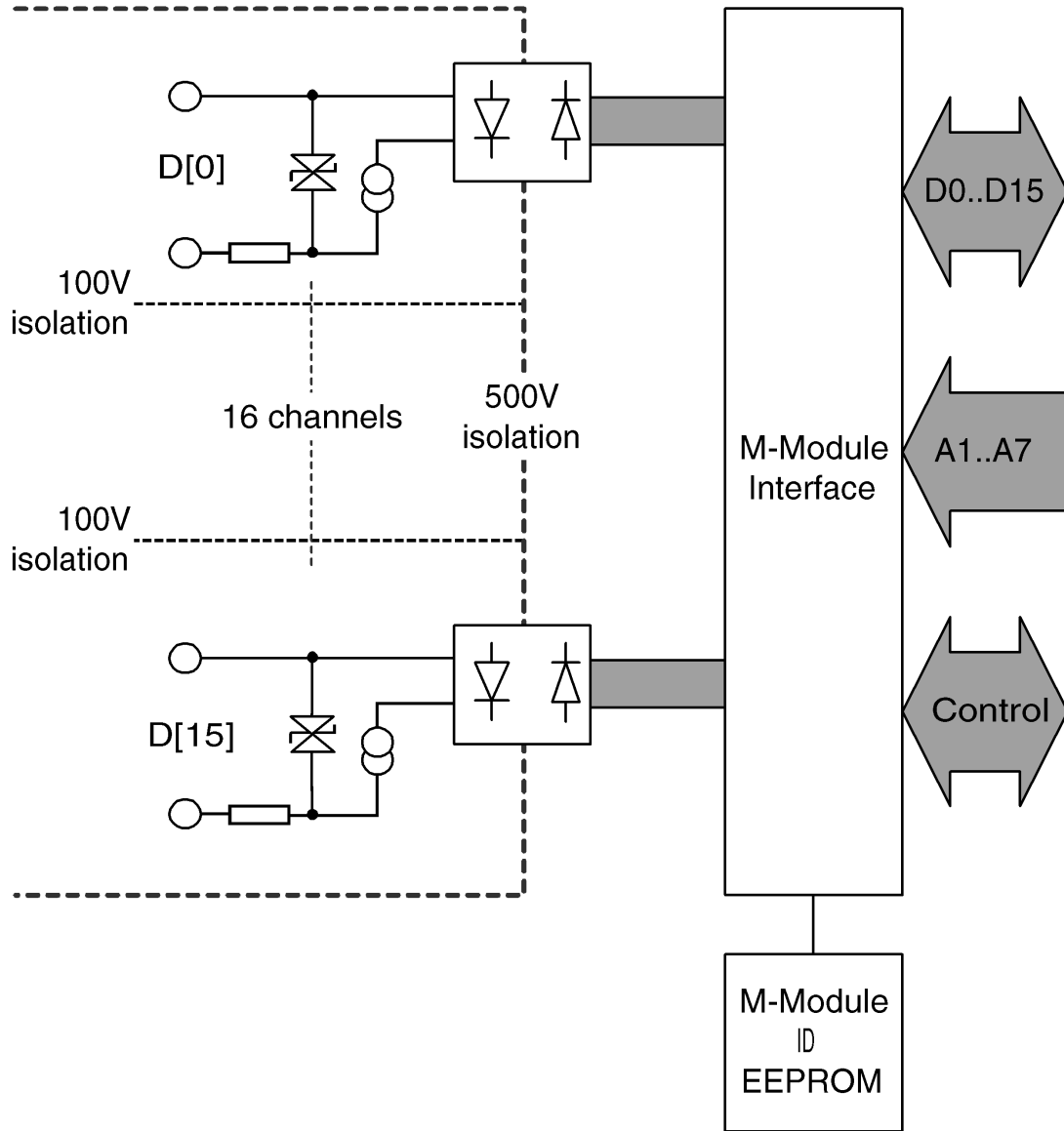

Related Products

Standard Hardware

04M082-00	M82, M-Module, 16 binary inputs, fully isolated, -40..+85°C
-----------	---

Please refer to our M-Module compare chart for a selection of further binary I/O functions.

Accessories

05M000-14	M-Module cable, 2.5m, with 44-pin HD-Sub plug/housing to pig tail
-----------	---

05M000-17	25 mounting screw sets to fix M-Modules on carrier boards
-----------	---

05M000-18	M-Module cable, 2 m, with 44-pin HD-Sub plug/housing to 50-pin D-Sub receptacle/housing
-----------	---

05M000-20	M-Module cable, 2m with 44-pin HD-Sub plug/housing to 44-pin HD-Sub plug/housing, (connecting 1:1)
-----------	--

Software

13M031-06	MDIS4/2004 low-level driver sources for M31/M32/M82
-----------	---

13M031-70	MDIS4/2004 Windows® NT4/W2K driver for M31/M32/M82
-----------	--

To use MDIS4 low-level drivers, you also need one of the MDIS4 system packages available for Windows®, Linux, VxWorks®, QNX®, RTX or OS-9 (MDIS4 = MEN Driver Interface System).

Documentation

20M000-00	M-Module draft specification, Rev. 3.0
-----------	--

20M082-00	M82 user manual
-----------	-----------------

21APPN001	Application Note: MDIS4 under LabWindows®/CVI
-----------	---

For the most up-to-date ordering information and direct links to other data sheets and downloads, see the M82 online data sheet under www.men.de. --> [Click here!](#)

Contact Information

Germany

MEN Mikro Elektronik GmbH
 Neuwieder Straße 5-7
 90411 Nuremberg
 Phone +49-911-99 33 5-0
 Fax +49-911-99 33 5-901
 E-mail info@men.de
www.men.de

France

MEN Mikro Elektronik SA
 18, rue René Cassin
 ZA de la Châtelaine
 74240 Gaillard
 Phone +33 (0) 450-955-312
 Fax +33 (0) 450-955-211
 E-mail info@men-france.fr
www.men-france.fr

UK

MEN Micro Ltd
 Whitehall, 75 School Lane
 Hartford, Northwich
 Cheshire UK, CW8 1PF
 Phone +44 (0) 1477-549-185
 Fax +44 (0) 1477-549-178
 E-mail info@menmicro.co.uk
www.menmicro.co.uk

USA

MEN Micro, Inc.
 PO Box 4160
 Lago Vista, TX 78645-4160
 Phone (512) 267-8883
 Fax (512) 267-8803
 E-mail sales@menmicro.com
www.menmicro.com

The date of issue stated in this data sheet refers to the Technical Data only. Changes in ordering information given herein do not affect the date of issue.

All brand or product names are trademarks or registered trademarks of their respective holders.

Information in this document has been carefully checked and is believed to be accurate as of the date of publication; however, no responsibility is assumed for inaccuracies. MEN Mikro Elektronik accepts no liability for consequential or incidental damages arising from the use of its products and reserves the right to make changes on the products herein without notice to improve reliability, function or design. MEN Mikro Elektronik does not assume any liability arising out of the application or use of the products described in this document.

The products of MEN Mikro Elektronik are not suited for use in nuclear reactors and for application in medical appliances used for therapeutic purposes.

Application of MEN's products in such plants is only possible after the user has precisely specified the operation environment and after MEN Mikro Elektronik has consequently adapted and released the product.

Copyright © 2005 MEN Mikro Elektronik GmbH. All rights reserved.