

SPECIFICATIONS

PRODUCT SPECIFICATIONS



**HIGH DYNAMIC RANGE
OF UP TO 112 dB
DIGITAL CMOS AREA SCAN
MONOCHROME
IEEE 1394 OUTPUT**

BASLER A600-HDR

Features/Benefits

- HDR feature allows capture of images with up to a 112 dB dynamic range
- The use of varying exposure times allows a high signal-to-noise ratio for all acquired gray values
- Different output formats are available to display the high dynamic range images
- 100% factory testing ensures consistent product quality
- Ultra compact size reduces the space needed in your application

Description

The A600 Series of high-performance, VGA resolution, digital cameras is ideal for price sensitive users seeking the advantages of digital video. The CMOS sensor used in A600 cameras is highly resistant to blooming and smearing. By capturing information at different gray values and various exposure times within one image, the A600f-HDR can generate a dynamic range of up to 112 dB. In addition to this high dynamic range, the signal-to-noise ratio for each gray value is exceptionally good compared to a purely logarithmic sensitivity curve. The output signal can be displayed in a linear 16 bit format (limited), by a Laplace conversion, by a tone mapping, or by using an exponential format (8 bit base, 8 bit exponent). Please see the user's manual for more detailed information.

Applications

- Outdoor systems
- Intelligent traffic systems
- Surveillance
- Any application requiring high dynamic range

Dimensions (in mm)

A600f (IEEE 1394)

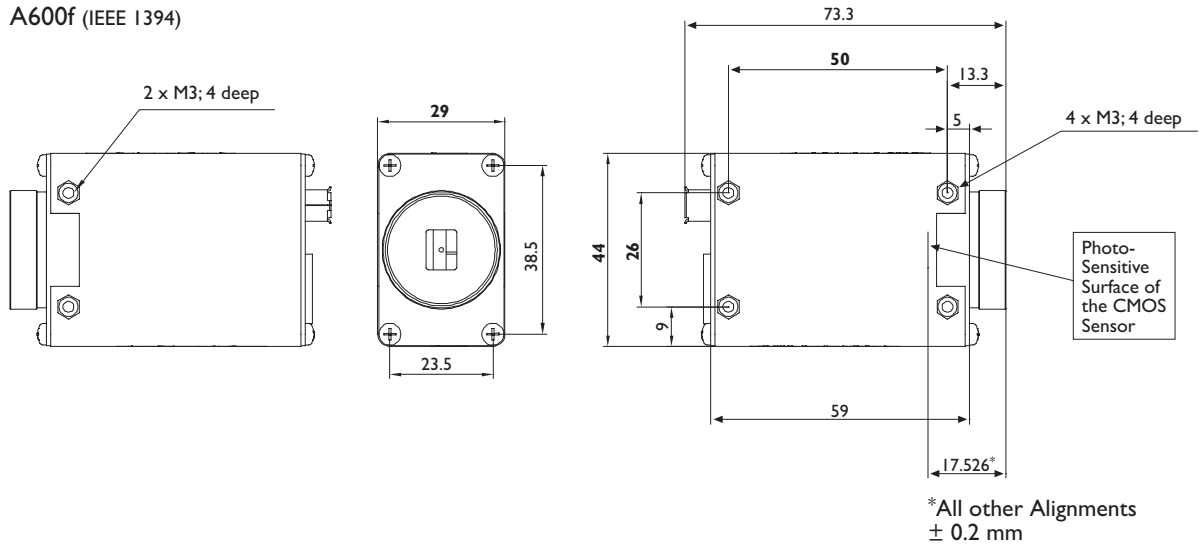

Specifications	A601f-HDR
Sensor Size (H x V Pixels)	656 x 491
Sensor Type	Progressive Scan CMOS
Pixel Size	9.9 μm x 9.9 μm
Max. Frame Rate (depends on dynamic range)	53.3 fps @ 48 dB ... 8 fps @ 112 dB
Color / Mono	Mono
Video Output Type	IEEE 1394
Video Output Format	Inside PC: 8 bit/pixel, 16 bit/pixel (linear or exponential), Laplace, Tone map, or Gamma
Power Requirements	+ 8 to + 40 VDC (12 VDC nominal), max. ~ 2 W
Lens Mount	C-Mount
Housing Size (L x W x H)	67.5 mm x 44 mm x 29 mm
Weight	max. 100 g (typical)
Conformity	CE, FCC

Specifications are subject to change without prior notice.

BASLER
VISION TECHNOLOGIES

Germany, Headquarters
Phone +49 4102 463 500
Fax +49 4102 463 599
vc.sales.europe@baslerweb.com

USA
Phone +1 610 280 0171
Fax +1 610 280 7608
vc.sales.usa@baslerweb.com

Singapore
Phone +65 6425 0472
Fax +65 6425 0473
vc.sales.asia@baslerweb.com

www.basler-vc.com